

## MONARCH GLIDE

### Wide Span pleated retractable insect screen

Horizontal slide manually operated

#### Applications

- Bifold doors
- Stacker Doors
- Outdoor Rooms

#### Features

- Pleated Pet Mesh 25mm Pleat
- +/- 5mm building tolerance
- Wide span capability
- Recess mount or Face mount with FMA
- Mesh retention clips
- Easy clean floor guide
- Quick to install
- Sliding Bar auto-stop
- Smooth and easy to open and close
- Supplied ready made or size adjustable kit



#### Overview

This modern stylish pleated screen is perfect for Bi-fold doors, stacker doors, large sliding doors, outdoor rooms or on openings that are more than 4.0m wide. The semitransparent mesh is designed to maximize ventilation without compromising the view.

Monarch Glide incorporates Seiki's wide screen technology, allowing the screen to span greater distance than Monarch Ex2 but still maintain a high level of insect protection. It operates easily, allowing the user to gently slide the screen to any position along the opening due to the unique cord operating system.

The cords assist the motion of the screen and combined with Seiki's originally designed mesh retention clips support the mesh in windy conditions. When not in use, the mesh stores almost invisibly off to the side of the opening inside the cartridge.

#### Size Range

**Single Slide**      **Max:** 3000mm high x 4600mm wide

**Double Slide**      **Max:** 3000mm high x 9200mm wide



## MONARCH GLIDE

Single Panel

SINGLE SCREEN									
Width Height	1701-1900	1901-2200	2201-2500	2501-2800	2801-3100	3101-3400	3401-3800	3801-4200	4201-4600
1700 - 1950	MGS-1919	MGS-1922	MGS-1925	MGS-1928	MGS-1931	MGS-1934	MGS-1938	MGS-1942	MGS-1946
1951 - 2200	MGS-2219	MGS-2222	MGS-2225	MGS-2228	MGS-2231	MGS-2234	MGS-2238	MGS-2242	MGS-2246
2251 - 2450	MGS-2419	MGS-2422	MGS-2425	MGS-2428	MGS-2431	MGS-2434	MGS-2438	MGS-2442	MGS-2446
2451 - 2700	MGS-2719	MGS-2722	MGS-2725	MGS-2728	MGS-2731	MGS-2734	MGS-2738	MGS-2742	MGS-2746
2701 - 2950	MGS-2919	MGS-2922	MGS-2925	MGS-2928	MGS-2931	MGS-2934	MGS-2938	MGS-2942	MGS-2946

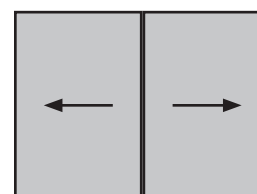

Double Panel

DOUBLE SCREEN									
Width Height	3401-3800	3801-4400	4401-5000	5001-5600	5601-6200	6201-6800	6801-7600	7601-8400	8401-9200
1700 1950	MGD-1938	MGD-1944	MGD-1950	MGD-1956	MGD-1962	MGD-1968	MGD-1976	MGD-1984	MGD-1992
1951 - 2200	MGD-2238	MGD-2244	MGD-2250	MGD-2256	MGD-2262	MGD-2268	MGD-2276	MGD-2284	MGD-2292
2251 - 2450	MGD-2438	MGD-2444	MGD-2450	MGD-2456	MGD-2462	MGD-2468	MGD-2476	MGD-2484	MGD-2492
2451 - 2700	MGD-2738	MGD-2744	MGD-2750	MGD-2756	MGD-2762	MGD-2768	MGD-2776	MGD-2784	MGD-2792
2701-2950	MGD-2938	MGD-2944	MGD-2950	MGD-2956	MGD-2962	MGD-2968	MGD-2976	MGD-2984	MGD-2992

**STANDARD FINISHES:** MF - Mill Finish  
 BK - Satin Black  
 WH - White

**ORDERING CODE:** S Single Slide  
 D Double Slide

**NOTES:** Other sizes are available but may not be represented above.  
 Size may NOT be stocked – May be “Order In”  
 Custom colours available on request but subject to conditions.

**MONARCH GLIDE**

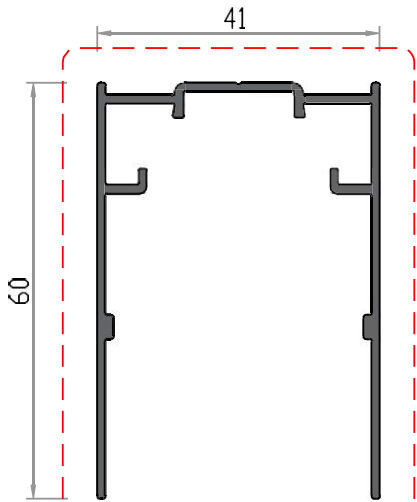

Top Rail

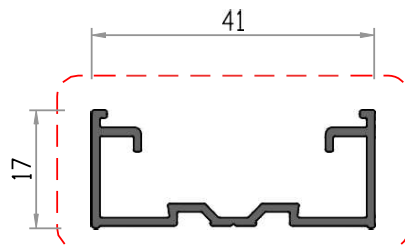

Bottom Rail

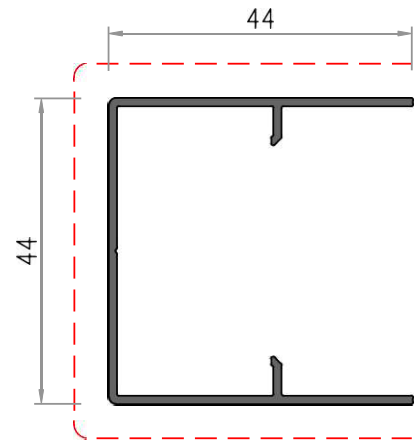

Housing

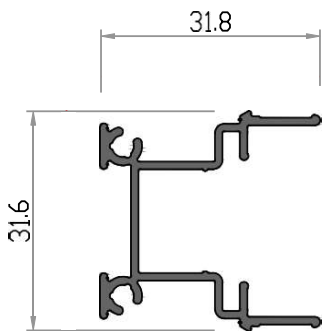

Inner Cartridge

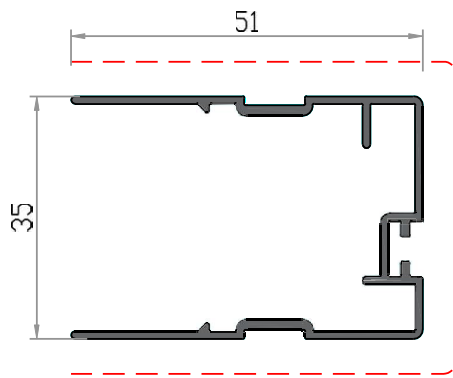

Sliding Bar

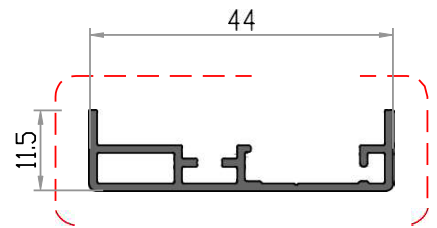

Catch Frame